

# Van

# MEGA



multi**truck**  
range

## TECHNICAL SPECIFICATIONS

	COMBUSTION ENGINES		ELECTRIC MOTOR
	Diesel 400	Diesel 500	8 or 12 batteries
Engine	Kubota	Kubota	General Electric 48V
Position	Transverse central	Transverse central	Transverse central
Capacity (cm <sup>3</sup> )	400	479	Electric motor with separate excitation and electronic variator
Max. power (kW CEE)	4	9.5	4
Torque (Nm at rpm)	14 at 2400	28.5 at 2500	-
Max. laden engine speed (rpm)	3200	3600	-
Fuel supply	Indirect injection	Indirect injection	Direct current
Alternator	500 W	500 W	-
Service battery	12V 40 Ah	12V 40 Ah	12V 40Ah
Traction battery			8 or 12 lead-gel batteries
Charger	-	-	220V 16A
Transmission	Automatic by variator	Automatic by variator	Automatic by variator
Steering	Rack and pinion	Rack and pinion	Rack and pinion
Braking	Dual circuit with limiter through load sensing valve Low level wear indicators Front disk diameter 210 mm Rear drum diameter 160 mm Mechanically operated parking brake on rear axle		
Suspension	Front: Independent MacPherson Strutt type Coil springs Independent rear suspension with coil springs		
Tyres	145/70R13	145/70R13	145/70R13
Tank	24L	24L	-
Performances:			
Max. speed (mph)	approx. 30	approx. 50	approx. 30
Autonomy (km)	approx. 650	approx. 600	approx. 60 to 100
Consumption (L/100km)	approx. 3.5	approx. 4	-

van

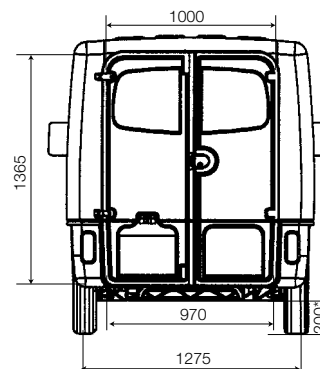
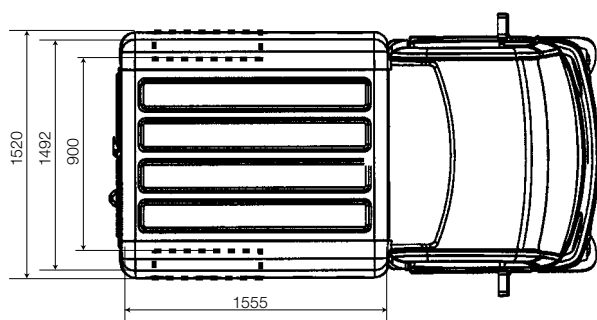
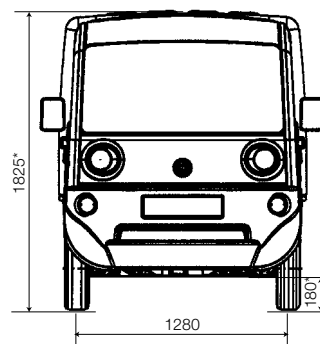
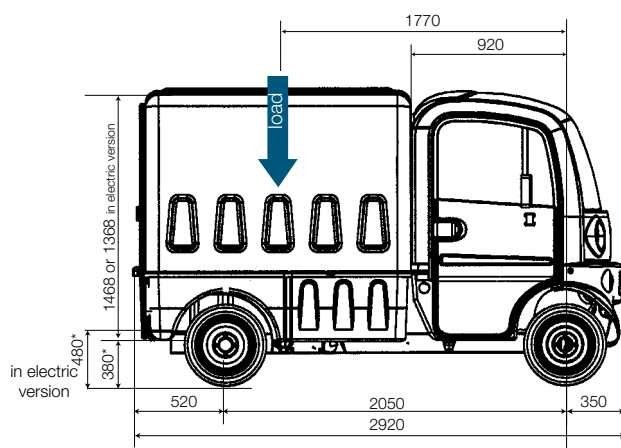

4 colour choice

### Dimensions (mm)

Wheel base	2050
Overall length	2920
Overall width (excluding rear view mirrors)	1498
Overall height	1825*
Bed interior length	1555
Max. interior width	1492
Min. interior width	900
Interior height	1468
	1368 in electric version
Interior volume (m3)	3
REAR doors opening width	1000
	970 below
REAR doors opening height	1365
	1350 except lock
Height from ground to trunk floor	380*
	480* in electric version
Front ground clearance	180*
Rear ground clearance	200*
Front track	1280
Rear track	1275
Rear overhang	520
Limit position of centre of gravity with respect to front axle axis	1770
Turning radius between walls (m) 3,9	3,9

\* Unladen vehicle ± 20 mm

### WEIGHT (kg)

	Combustion engines		Electric Motor			
	Diesel 400	Diesel 500	VSP 8 batt.	VSP 12 batt.	TQM 8 batt.	TQM 12 batt.
Weight in unladen condition	400	440	610	720	610	720
Pay load	275	460	275	275	415	305
Total authorised laden weight	675	900	885	995	1025	1025
Max. tolerated load on axle						
FRONT	390	450	510	510	510	510
REAR	450	690	690	690	690	690

### STANDARD EQUIPEMENT

- 2 rear lockable doors
- Steering lock
- 2-speed motor wiper
- Electrical windscreen washer
- Hazard lights
- Inertia safety belts
- Rearview mirror
- Left and right wing mirrors
- Tinted glass
- 3-speed heater with defrost
- Engine soundproofing
- "Lights on" warning buzzer
- Interior lighting controlled by door switch
- Ashtray and cigarette lighter
- Centre storage pocket
- Pre-wired for radio
- Sun visor with passenger side make-up mirror
- Lockable fuel tank cap
- Rubber floor mats
- Wheel trims

### OPTIONAL EQUIPEMENT

More options are available  
(see individual specification pages)